

HILUX



TOYOTA TANZANIA



THE NEW
HILUX

LIMITLESS

SINCE 1968

5 YEARS
TOYOTA
WARRANTY
or 150,000kms



TOUGH LEADS THE WAY

MEET THE TORQUE MASTER

Hilux challenges the perception of power with its brand new diesel engines. New 2.4 and 2.8 GD engines are performing superbly thanks to new torque technology which dramatically increases torque in low to medium speed ranges and unprecedented acceleration. It also contributes to Hilux's exceptional towing capacity. These engines are designed to keep noise levels down and efficiency up. In fact, the refined sound insulation can make you forget that you're driving a pick-up. The same is true for the efficient new 6-speed manual and new 6-speed automatic transmissions: it adds to the premium SUV-style driving sensation.

Choose the engine for the work you do and the way you want to roll:

Engine

2.4 GD-6

Diesel D-4D 6M/T or 6A/T

Engine

110kW/150HP

Torque

400 Nm

Drive

4x2 or 4x4

Available on

Work, Country,
Comfort, Active

Engine

2.4 GD-6

Diesel D-4D 6M/T

Engine

110kW/150HP

Torque

400 Nm

Drive

4x4

Available on

Work, Country,
Comfort

Engine

2.8 GD-6

Diesel D-4D 6A/T

Power

150kW/204HP

Torque

500 Nm

Drive

4x4

Available on

Executive,
Adventure





MORE POWER

Up to **47%** more power and **54%** more torque! The newly developed GD engines features vastly evolved low-speed torque. In addition, manageability of the effective speed range has been improved, realizing unprecedented acceleration performance.

MORE EFFICIENT

Powerful and efficient. The newly developed GD engines features vastly improved fuel economy. Up to **14%** on fuel savings comparing to the previous generation of engines. That means you can travel up to **130*** km further and get more things done!

Powerful new engines offer high torque and power while contributing to excellent fuel economy and quietness.



NEW ENGINE (GD)

ENGINE SPECIFICATIONS	1GD-6AT	2GD-6MT
Displacement (litres)	2.8	2.4
Transmission	6-automatic	6-manual
Maximum power output (kW)	150	110
Maximum power output (HP)	204	150
Maximum torque (Nm)	500	400
Combined fuel cons. (l/100 km)		

PREVIOUS ENGINE(KD)

ENGINE SPECIFICATIONS	1KD-5AT	1KD-6MT	2KD-6MT	2KD-5MT
Displacement (litres)	3.0	3.0	2.5	2.5
Transmission	5-automatic	6-manual	6-manual	5-manual
Maximum power output (kW)	120	120	75	75
Maximum power output (HP)	163	163	102	102
Maximum torque (Nm)	360	360	260	200
Combined fuel cons. (l/100 km)	9.3	8.3	8.0	8.0

IMPROVEMENTS	1GD vs. 1KD	1GD vs. 1KD	2GD vs. 2KD	2GD vs. 1KD
Displacement (liters)	2.8 vs 3.0	2.8 vs 3.0	2.4 vs 2.5	2.4 vs 3.0
Transmission	automatic	manual	manual	manual
More POWER	+8%	+8%	+47%	-8%
More TORQUE	+25%	+22%	+54%	+17%
Better fuel ECONOMY	+9%	+9%	+10%	+14%

*Efficiency depends on fuel quality, driving style and road conditions.



POWER YOUR WAY

SMOKING HOT DESIGN

Few pick-ups are as proud to add mud or sand to their exterior as Hilux. It's rugged design is made to look its best on any job, challenge or outing – flaming hot or icy cold. This is Toyota signature design at its most audacious, full of strong shapes and sharp corners that reinforce intelligent toughness. Everything from the 3D grille – now integrated into the bonnet for a powerful, seamless look and framed by LED lights – to the muscular wheel flare and the dynamic sidelines spells sophisticated power. The stylish belt line along the windows and a wide choice of wheels add eye catching highlights.



PLAYTIME



WORK HARD, TOW EASILY

They say breakfast is the most important meal of the day. So if you wonder where the Hilux gets its strength from, it's simple: this remarkable pick-up is designed first and foremost as a work-horse with a towing capacity of 3.5* tonnes. While engine torque has been increased, the cooling performance of both engine and transmission have also been improved for effortless towing. Whether you want to tow grain, another vehicle or a caravan, the new Hilux tackles it with ease. It's also equipped with Trailer Sway Control (TSC) to ensure the vehicle stays steady when faced with crosswinds or changing road surfaces.

*Towing capacity varies from models, please check with Toyota dealership for specific vehicle



TAKE CHARGE

QUALITY, DURABILITY AND RELIABILITY – NO TERRAIN TOO TOUGH

Forget tough days at the office – whether faced with difficult terrain or the stresses of everyday life, nothing can faze the new Hilux. That's because this pick-up is tougher than ever. Building on its legendary strength and reliability, the Hilux frame and body structure have been redesigned to ensure toughness, while a stronger, wider under-body now offers greater protection. In fact, all the components of the Hilux are made to withstand the most rigorous tests. The new frame also contributes to improved handling and ride comfort, working hand-in-hand with the new suspension and the newly designed gear ratios. To help you get through challenging environments, you can always rely on Active Traction Control (A-TRC) and the rear differential lock to ensure optimal traction. All these refinements add to Hilux's unique sense of effortless driving, on or off-road.

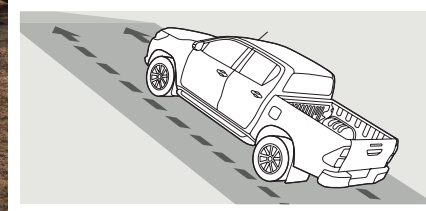

Hill-start Assist Control (HAC) automatically maintains the brake force for up to two seconds after the brake pedal is released to give you a smooth start on steep inclines – without rolling back.



LUXURY INTERIOR



TOUGH OUTSIDE, COMFORTABLE INSIDE

This pick-up is all about quality surroundings and attractive, durable materials paired with the latest technology to maximize your comfort. A first-in-class electronic control to reduce body pitch and bounce ensures the ride feels as smooth as in a premium SUV. Equally, the newly designed adjustable leather seats offer greater comfort and support, while the height and depth adjustable steering wheel can be set to your ideal seating position. Automatic air conditioning and a clean air filter are also available to keep your temperatures at comfortable level



(1) The rear seats are split 60:40 and can be tipped up for added cargo space.

(2) Whether you're heading off-road or to the office, the cool box above the glove compartment keeps your drinks chilled. Hilux is generous with an astounding 11 storage areas positioned around the cabin.



Extra Cab



Payload 810 - 845 kg
Gross vehicle weight 2860 kg
Engine 2.8 GD-6 D-4D
Drive 4x4
Transmission 6 M/T

Double Cab



Payload 800 - 930 kg
Gross vehicle weight 2810 - 2910 kg
Engine 2.4 and 2.8 GD-6 D-4D
Drive 4x2 or 4x4
Transmission 6 M/T or 6 A/T



PICKING UP ESSENTIALS



Single Cab



Payload 885 - 975 kg
Gross vehicle weight 2870 kg
Engine 2.4 and 2.8 GD-6 D-4D
Drive 4x2 or 4x4
Transmission 6 M/T

A BODY STYLE TO SUIT ALL YOUR NEEDS

The new Hilux has a body for every purpose. Whatever you're picking up, whether it's work or play, you'll find the perfect vehicle.

The interior has been redesigned to provide more space for all passengers. At the front, there's more shoulder room and headroom. The seat adjustment range has also been widened to suit individual body shapes. Plus, increased legroom at the rear means everyone arrives completely relaxed, ready for the next Hilux adventure.



J-Deck, optional on Double Cab, is the convenient system with outside hooks that gives you an answer to a whole range of business scenarios. For extra protection choose durable bed liner option.



MISSION CONTROL

TECHNOLOGY

Hilux is equipped with a range of innovative technology, designed to make every journey more relaxing. Take the tablet-style touch 8" screen, which combines plenty of multimedia features. It is connected to a refined audio speaker system, while you adjust the volume via the steering wheel. Another Hilux first, the new 4.2" Multi-Information Display (MID) in the instrument panel incorporates 3D messages to help you drive more efficiently. It also holds the trip computer that displays essential journey data. All these functions can be easily accessed via the handy steering wheel controls.



8" Touch screen

This multimedia system will allow you to experience a world of information and entertainment in a stylish tablet-style 8" display. For enhanced security, there is a convenient reverse camera.

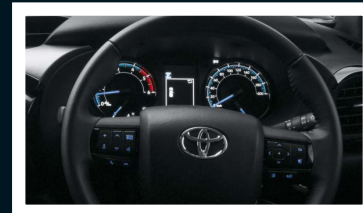

Multi-information display

The new color multi-information display for easy access to essential journey information.

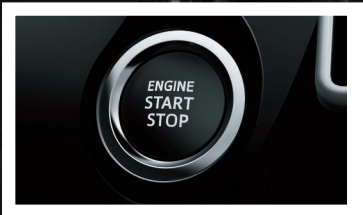

Smart Entry & Start System

This allows you to unlock the car simply by pressing a button on the door handle. The start/stop button starts the engine. All you need to do is carry the Smart Entry key.



4-Wheel-Drive switch

For added convenience and style, the Hilux is also equipped with a 4-Wheel-Drive switch instead of a lever.

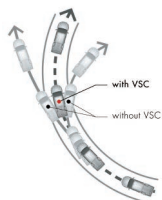

Vehicle Stability Control (VSC)

VSC automatically activates each individual brake as needed and controls engine output to help maintain stability and prevent skidding when turning sharply or cornering on slippery road surfaces.



Supplemental Restraint System (SRS) – 7 airbags

Hilux is fitted with up to seven airbags. They include driver's knee airbag, SRS airbags for both driver and front passenger, side airbags for the front seats, and SRS curtain shield airbags covering both the front and rear seat passengers.



PLAY SAFE



HIGH NOTES FOR SAFETY

The Hilux excels when things get tough. After all, it's built to withstand the most testing situations. The redesigned frame and body structure features extensive use of High-Tensile Strength Steel (HTSS) to ensure all occupants are protected in an accident. The side members and cross members have been reinforced and enlarged helping to absorb even more energy in an impact and distribute the force effectively. Other active safety technology including Vehicle Stability Control (VSC) and up to seven Supplemental Restraint System (SRS) airbags also contribute to Hilux's excellent crash performance.

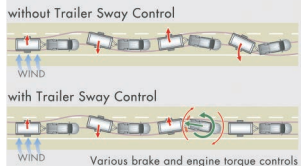

Trailer Sway Control (TSC)

TSC suppresses any trailer sway caused by wind, bumpy roads or steering etc. whenever you are towing. With sensors detecting yaw, acceleration and steering, TSC uses deceleration control and yaw moment to limit sway. The slip indicator bleeps when TSC is activated, and to warn drivers behind, the stop lamps are illuminated.

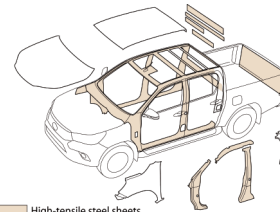

Robust body

All the sections of the body structure, including crossmember, side rail and suspension tower, have been reinforced for exceptionally high rigidity.

HILUX GRADES

WORK & COUNTRY

Main features:

- Available on Single and Double Cab models
- Power steering
- 8" multimedia touchscreen
- Apple CarPlay and Android Auto
- Bluetooth connectivity
- USB input
- Steering wheels with switches
- 2 speakers
- PVC seat material
- Air conditioner (manual)
- Tilt and telescopic steering adjustment
- Bench front seat
- Glove box with key
- Color painted or black front bumper
- Color painted back bumper with steel step
- Black front grill
- Mud guards (front and rear)
- Deck guard frame
- Black door handles and black outside mirrors
- ABS Antilock Braking System
- EBD Electronic Brake Force Distribution
- BA Brake Assist
- High mounted brake light (LED)
- Driver & passenger airbags (SRS)
- Driver knee airbag (SRS)
- ISOFIX points for child safety seats
- Child lock

- 2 bulb halogen headlamp
- Steel wheels
- Tire dimensions:
 - 205 R16C
 - 215/65 R16C
 - 225/70 R17C
- 80L fuel tank capacity
- Rear differential lock (for 4x4)
- 1 power socket 12V
- Engine oil level warning
- Pitch and Bounce Control
- 4WD switch (for 4x4 models)
- Immobilizer
- Steel spare tire



* Shown specifications may differ from model to model, please ask your Toyota dealership for more details.

HILUX GRADES

COMFORT

Main features (additional on COUNTRY)

- Available on Single and Double Cab models
- Power door lock
- Wireless power door lock
- Power windows (auto up/down for driver)
- Outside mirrors electrically adjustable
- Separate front seats
- Fabric seat material
- Seat back pocket
- Multi information display, DOT type
- 2 or 4 speakers
- Side steps with black cover, narrow
- Color painted front grill
- Eco drive mode
- Tire dimensions:
205 R16C
225/70 R17
- Immobilizer and siren
- VSC Vehicle Stability Control
- HAC Hill Start Assist Control
- TSC Trailer Sway Control



* Shown specifications may differ from model to model, please ask your Toyota dealership for more details.



12:00

TOYOTA

DRIVE MODE SELECTOR: TRACK, NORMAL, SPORT, OFF ROAD, ECON, L4, L4+ (LOCK), L4+ (UNLOCK), L4+ (LOCK), L4+ (UNLOCK)

TOYOTA HILUX

HILUX

TOYOTA

DRIVE MODE SELECTOR: TRACK, NORMAL, SPORT, OFF ROAD, ECON, L4, L4+ (LOCK), L4+ (UNLOCK), L4+ (LOCK), L4+ (UNLOCK)

26.5

AC AUTO

DRIVE MODE SELECTOR: TRACK, NORMAL, SPORT, OFF ROAD, ECON, L4, L4+ (LOCK), L4+ (UNLOCK), L4+ (LOCK), L4+ (UNLOCK)

ESP OFF

TRAIL BRAKE

HILUX GRADES



ACTIVE



Main features (additional on COMFORT)

- Available on Double Cab models
- Available on Manual and Automatic transmission
- Power door lock (auto/speed sensitive)
- 6 speakers
- Multi information display (Color TFT)
- Chromed door handles & outside mirrors
- Outside mirrors electrically adjustable & retractable
- LED type front fog lamps
- 4-bulb halogen headlamp
- Alloy wheels
- Tire dimensions 265/6 R17
- Immobilizer + Siren + Ultrasound

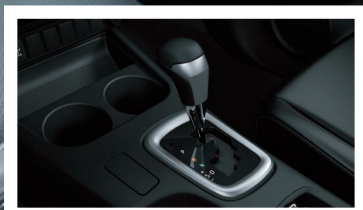

HILUX GRADES



EXECUTIVE



Main features (additional on ACTIVE)

- Available on Double Cab models
- Power windows (auto up/down all)
- Window jam protection (all)
- Smart entry & Start system (“keyless” Entry & Start)
- Tilt and telescopic steering adjustment with electrical lock
- Dual Automatic air conditioner*
- Glove box with key and damper
- Leather steering wheel
- Leather door trim
- Leather seats
- Power seat adjustment for driver
- 60/40 foldable rear seats
- Front cool box
- 2 power sockets 12V
- Chrome details on parking brake
- Light control system
- Follow me home lighting system
- LED type main headlamps
- Auto levelling main headlamps
- Chromed front grill
- Chromed rear bumper
- Without deck guard frame
- Cruise control
- Reverse camera (back monitor)
- Front and rear parking sensors
- Side airbags & curtain airbags (SRS)



STAND OUT FROM THE CROWD

The all-new Hilux Double Cab Adventure stands out from the crowd through its enhanced bold exterior styling that includes black engine hood moulding and black treatment on the door handles, side mirrors and front and rear fenders. The boldness continues with aggressive front LED headlights and Adventure black electric and retractable side mirrors that make the Hilux Adventure hard to miss.





ADVENTURE

Main features (additional on EXECUTIVE)

- Available on Double Cab models
- "Adventure" engine hood molding
- Grey skid plate
- "Adventure" grille
- "Adventure" front fog bezels
- "Adventure" over fenders
- Black outside door handles
- "Adventure" tailgate garnish
- "Adventure" dark grey leather seats
- Black interior roof lining
- Black chrome door trims with blue illumination
- Black chrome for the instrument panel
- "Adventure" design alloy wheels
- Tire dimensions 265/60 R18





TOUGH LOOKS WHATEVER THE COLOUR

8 COLOURS TO MIX WITH
SAND RUBBLE OR MUD



Orange Metallic (4R8)



Attitude Black Mica Metallic (218)



Super White II (040)



Silver Metallic (1D6)



Gray Metallic (1G3)



Crimson Spark Red Metallic (3T6)



Avant-Garde Bronze Metallic (4V8)



Nebula Blue Metallic (8X2)



SPECIFICATIONS

ENGINE	2.4 GD-6 D-4D Diesel 6M/T	2.8 GD-6 D-4D Diesel 6A/T	5L-E
Engine code	2GD-FTV	1GD-FTV	
Number of cylinders	4-cylinder, In-line	4-cylinder, In-line	4-cylinder, In-line
Valve mechanism	16 Valve, DOHC	16 Valve, DOHC	16 Valve, ACT
Fuel system	Common Rail Diesel	Common Rail Diesel	Electronic injection
Displacement (cc)	2393	2755	2986
Bore × stroke (mm × mm)	92.0 × 90.0	92.0 × 103.6	99.5 × 96
Compression ratio	15.6	15.6	22,2
Maximum power output (DIN ch)	150	204	95
Maximum power output (kW/rpm)	110 @ 3400	150 @ 3000 - 4000	70@4000
Maximum torque (Nm/rpm)	400 @ 1600–2000	500 @ 1600–2800	197@2200
PERFORMANCE			
Maximum speed (km/h)	170	175	170
SUSPENSION			
Front suspension	Independent front suspension, double wishbone with coil springs		Shock absorbers with coil springs
Rear suspension	Leaf spring/ Rigid axle		Leaf spring suspension
BRAKES			
Front brakes		Ventilated disc brake	
Rear brakes		Leading trailing drum brake	
Transmission	6 speed manual	6 speed automatic	5 speed manual
GEAR RATIO			
1st	4.784	3.600	4.313
2nd	2.423	2.090	2.330
3rd	1.443	1.488	1.436
4th	1.000	1.000	1.000
5th	0.777	0.687	0.838
6th	0.643	0.580	
Reverse	4.066	3.732	4.220
Differential Gear Ratio	3.583	3.909	4.300

* Shown specifications may differ from model to model, please ask your Toyota dealership for more details.

SPECIFICATIONS

DIMENSIONS & WEIGHTS	Single Cab	Extra Cab	Double Cab
Exterior length, min–max (mm)	5265–5325	5325	5325
Exterior width, min–max (mm)	1800	1855	1855
Exterior height (mm)	1795	1810	1815
Front tread, min–max (mm)	1500–1510	1540	1540
Rear tread, min–max (mm)	1510	1550	1550
Front overhang, min–max (mm)	990	985	985
Rear overhang, min–max (mm)	1195–1255	1255	1255
Wheelbase (mm)	3085	3085	3085
Interior length (mm)	932	1404	1697
Interior width (mm)	1481	1481	1480
Interior height (mm)	1175	1168	1170
Deck length (mm)	2315	1808	1525
Deck width (mm)	1575	1540	1540
Deck height (mm)	480	480	480
Gross vehicle weight, min–max (kg)	2870	2860	2910
Kerb weight, min–max (kg)	1900–1990	2000–2060	2020–2135
Payload, min–max (kg)	885–975	810–845	800–930
Fuel tank size (L)	80	80	80
Towing capacity with brakes, min–max (kg)	2000–3500	3500	3500
Towing capacity without brakes, min–max (kg)	750	750	750
Turning circle, min–max (tyres, m)	6.3–6.4	6.4	6.4
Turning circle, min–max (body, m)	6.7	6.7	6.7
OFF ROAD			
Min. running ground clearance (mm)	294	311	310
Approach angle (°)	29	29	29
Departure angle (°)	25	26	26

* Shown specifications may differ from model to model, please ask your Toyota dealership for more details.

SPECIFICATIONS

Double Cabin

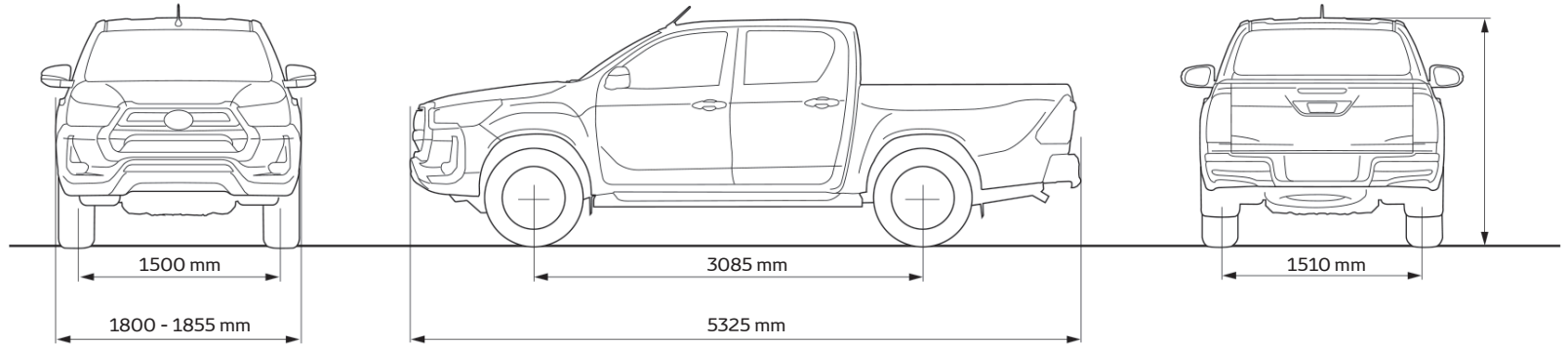

Extra Cabin

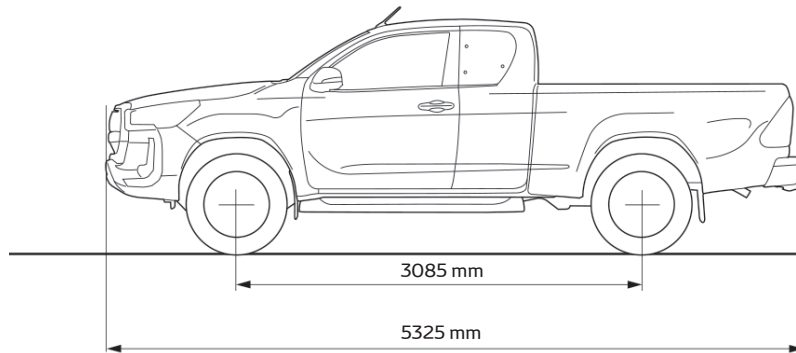

Single Cabin

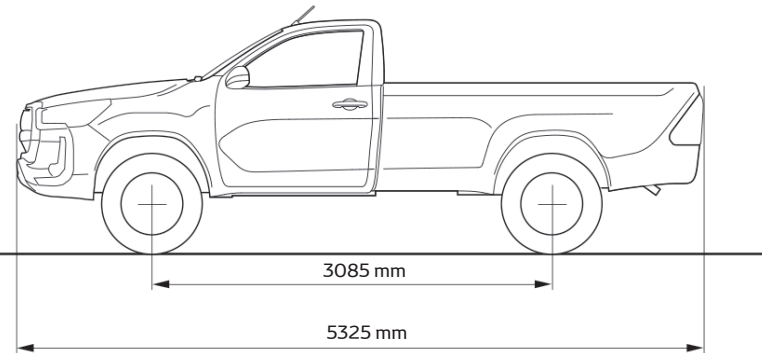

COMPLETE PEACE OF MIND WITH TOYOTA.

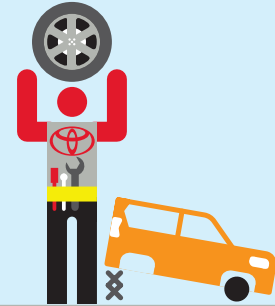
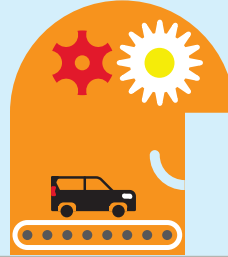
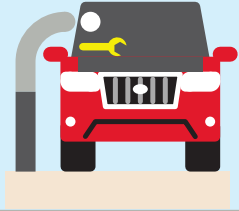

Toyota Quality Service

Your Toyota dealership will advise you on your vehicle's service requirements. It will need a health and safety check at least once a year. An intermediate check is necessary every year or 5,000 km.

Toyota Low Maintenance Costs

All Toyota vehicles are designed and engineered to minimize your maintenance costs. This includes fewer parts that require servicing and, equally important, is that Toyota vehicle technology is made easily accessible so that maintenance labor time is less and pricing is competitive.

Toyota Genuine Parts

Providing the reassurance of Toyota quality, only genuine and approved components are used on your vehicle. If the vehicle is damaged, its design helps minimize the cost of repair because the most expensive-to-replace parts are deliberately located away from common damage zones. The result is ultimately less expense for parts and labor.

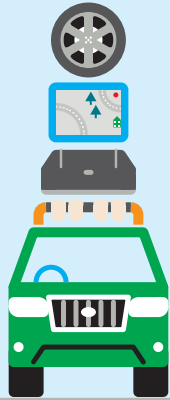

Toyota Accessories

Toyota genuine accessories are designed and manufactured with the same care, quality and attention to detail as Toyota vehicles. Adding a touch of style, comfort, convenience and practicality, they are tested for exceptional durability to enhance the enjoyment of your new vehicle. All accessories are covered by a 1-year warranty.



Toyota Comprehensive Warranty

Every new Toyota comes with a 5 years or 150,000 KM vehicle warranty, whichever comes first. This covers any defect caused by a manufacturing fault. In addition, a 60 months or 150,000 KM paint warranty protects against defects and surface rust caused by a manufacturing fault (except for deck panels of pick up trucks).



Toyota Added Security

Toyota's comprehensive security system withstands the insurance industry's rigorous five-minute attack test. The alarm system and engine immobilizer are approved by major insurance companies.



**FOR MORE INFORMATION ABOUT HILUX,
TEST DRIVES AND QUOTATIONS, PLEASE
CONTACT YOUR NEAREST TOYOTA DEALERSHIP.**

To the best of our knowledge, all information in this brochure is correct at time of going to print. Details of specifications and equipment provided in this brochure are subject to local conditions and requirements and may, therefore, vary from models available in your area. Please inquire with your local dealership for details on your local specifications and equipment. • Vehicle body colors may differ slightly from the printed photographs in this brochure. • The readability of QR Codes® present in this brochure may differ according to the scanner used. Toyota cannot be held responsible should your device not be able to read any QR Codes® or interactive content markers. • Africa Mobility Solutions (Pty) Ltd reserves the right to alter any details of specifications and equipment without prior notice. • © 2020 Africa Mobility Solutions (Pty) Ltd. ('AMS'). • No part of this publication may in any way be reproduced without the prior written approval of Africa Mobility Solutions (Pty) Ltd.

08/2021/HILUX/CFAO/AMS

